

TP9000

*Electronic Programmable
Room Thermostat plus
Domestic Hot Water Timer*



Installation Instructions
User Instructions

Danfoss



Index

Index

Installation Instructions **3-14**

Product Specification	3
Installation	4
Cable Access and Wiring	5
Installer Advanced Programming Options	8

User Instructions **15-31**

What is a Programmable Room Thermostat	15
Preset programmes	17
Setting Date and Time	18
Changing Preset Programmes	20
User overrides	27
User Advanced Programming Options	33
Overview of Installer Selectable Features	37
Setting References	39

Installation Instructions



Please note: This product should only be installed by a qualified electrician or competent Heating installer, and should be in accordance with the current edition of the IEEE wiring regulations.

Product specification

Specification	230V model	24V model
Power supply	230 Vac, $\pm 15\%$, 50/60 Hz	24 Vac, $\pm 15\%$, 50/60 Hz
Switching action	2 x SPDT internally linked, Type 1BS	
Unit switch rating	230 Vac, 3(1)A	24Vac, 3(1)A
Memory Backup	Retained for life of product	
Heat Temperature Range Setting	5°C - 30°C	
Factory Set Calendar Clock	Automatic Summer/Winter time change	
Remote Sensor Inputs ('A' models only)	Can be set by installer for remote sensor, limited sensor, window contact, tele-switch or outdoor sensor	
Programme resolution	± 1 minute	
Timing Accuracy	± 1 minute	
Dimensions, mm (W, H, D)	135 x 88 x 32	
Design standard	EN 60730-2-7 +EN60730-2-9	
Control Pollution Situation	Degree 2	
Rated Impulse Voltage	2.5 kV	
Ball Pressure Test	75°C	

Installation

- Remove wallplate from unit by unscrewing the two screws on the bottom edge of the unit.
- From the top left hand corner of the wallplate, there must be clearances of at least 140 mm to the right, 15mm to the left, 30mm above and 100mm below in order to mount the plug-on module.
- The wallplate must be securely mounted either directly to the wall using suitable wood screws or to a flush mounted 1-gang electrical accessory box using M3.5 screws.
- Cable access can either be from behind for concealed cabling, or from below for surface cabling. If surface cable is used, cut out cable access slot on plug-on module prior to mounting.
- For wiring connections refer to diagram on page 6.

The TP9000 is double insulated and does not require an earth connection, however a parking terminal is provided on the wallplate. This is clearly marked with an Earth symbol.

- Prior to mounting the plug-on module, DIL switches on the rear of the plug-on module must be set. See diagram below for available options.
- Mount plug-on module to wallplate by locating tabs on top of wallplate in apertures on rear of module, hinge down and press firmly to wallplate before tightening securing screws on bottom of wallplate.

- Prior to mounting the unit the 2 DIL switches on the rear of the unit have to be moved to the required position. The factory presets are shown below.

Sw. No.	OFF	ON
1	Keyboard disabled	Keyboard enabled
2	Reset disabled	Reset enabled

IMPORTANT: The supply to this unit should be wired via a double pole isolation switch in accordance with BS EN60730-1, i.e. one which provides air gaps of at least 3mm in both poles of the mains, and incorporates a 3 amp fuse. It is strongly recommended that solid conductors be used.

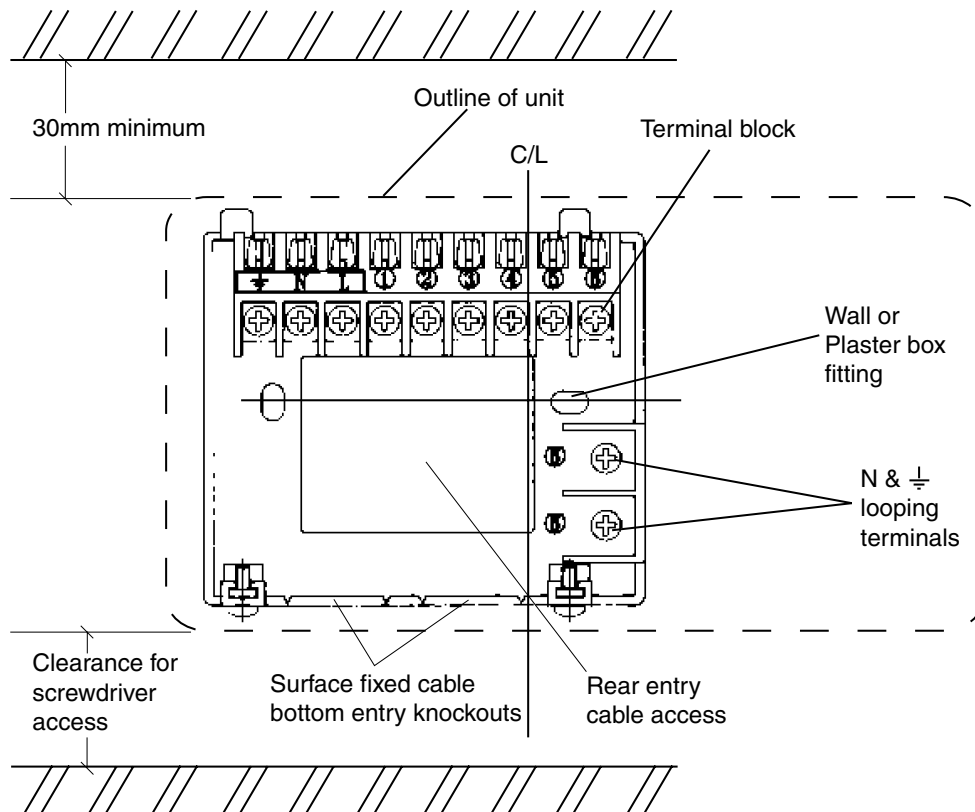

❑ **Thermostat and Remote Room Sensor:**

Fix at a height of approximately 1.5m from the floor, away from draughts or heat sources such as radiators, open fires or direct sunlight.

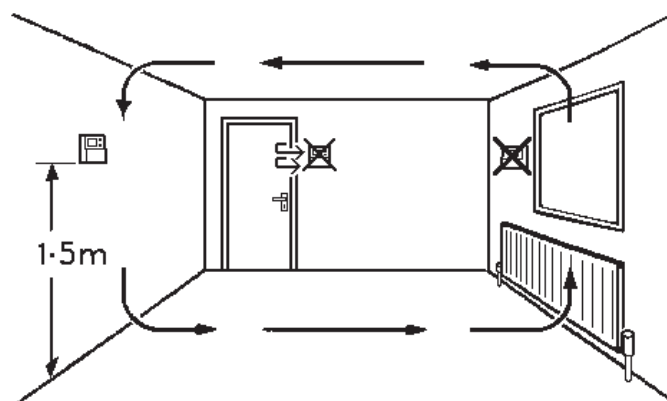

NOTE:

The TP9000 does not have voltage free contacts, therefore it is NOT suitable for connection to extra low voltage equipment (i.e. > 50 Volts).

Remote Sensor to be wired with 1mm 2 core double insulated cable only. Cable length should not exceed 50 metres. Sensor cable should NOT be run parallel to mains cable.

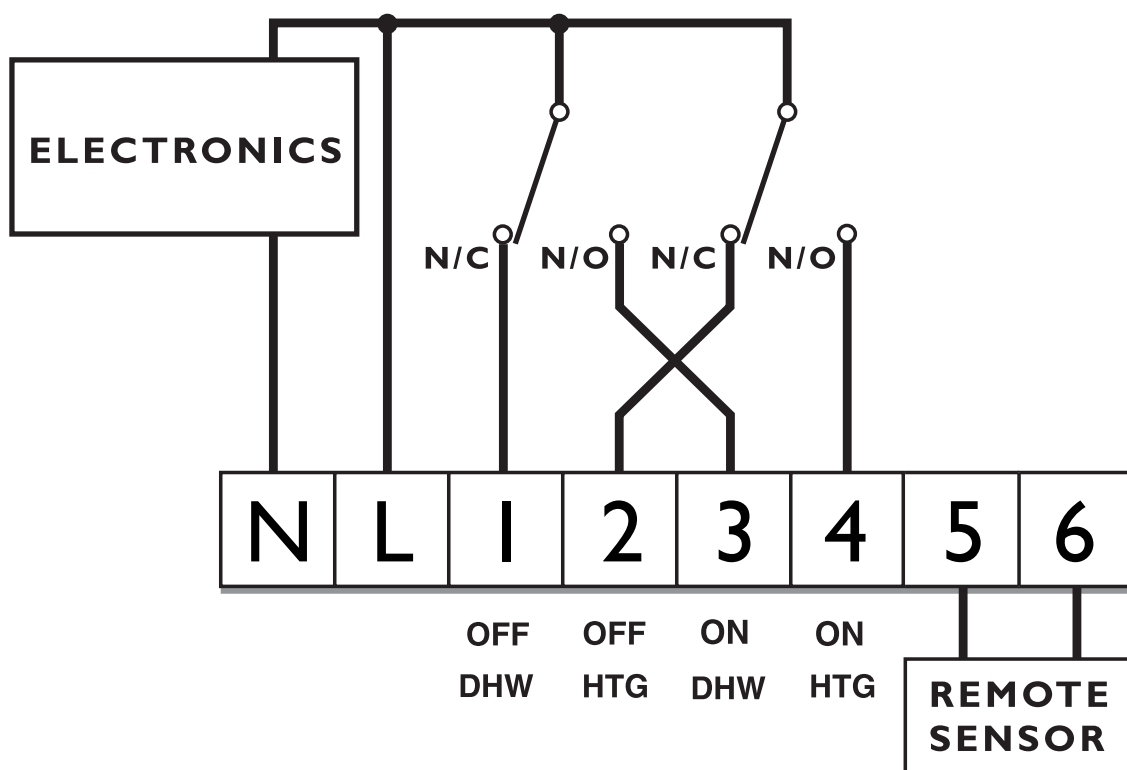

Remote sensor inputs

The TP9000 incorporates an input which can be used to connect one of the following:

- 1) remote room temperature sensor
- 2) limit sensor, for example, floor temperature sensor (sold as accessory).
- 3) window contacts, card reader contacts, outdoor sensor (sold as accessory) or teleswitch contacts.

See **Installer Advanced Programming Options** for set-up instructions.

Remote sensor inputs

Terminals 5 and 6 are the designated remote sensor inputs. These can be found on the top right hand side of the wallplate.

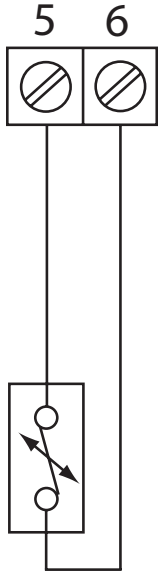

Configured for remote room, limit or outdoor sensor

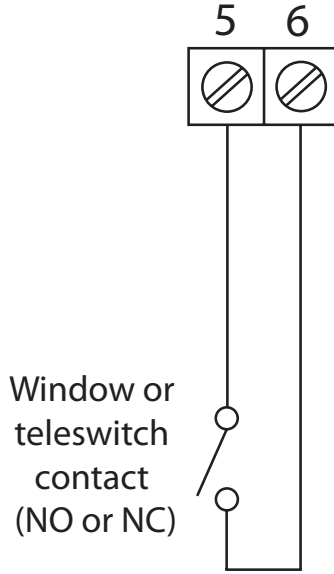

Window or teleswitch contact (NO or NC)

Configured for window contact or other contact such as teleswitch

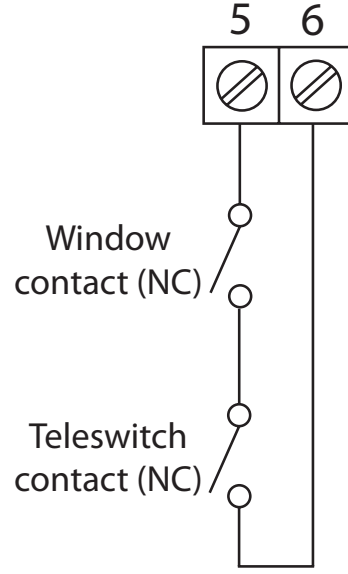

Window contact (NC)

Teleswitch contact (NC)

Configured for window contact and other contact such as teleswitch

Installer advanced programming options

TP9000 incorporates a number of advanced features which can be set by the user. These are accessed via a User Advanced Programming Mode, please refer to **User Advanced Programming** in the user instructions for details (see page 33)

Installer advanced programming options

TP9000 incorporates an additional number of advanced features which can be set by the installer to improve the operating efficiency of the system and where required, to change the user functionality of the product. These are accessed via an Installer Advanced Programming Mode. These settings are optional and need only be made if there is a demand for the enhanced functions.

Service Interval Timer

Instructions on how to access this feature are available from our customer support desk. Please note these are only issued to boni-fide Heating installers.

Entering Installer Advanced Programming Mode

To access the Installer Advanced Programming Mode follow the steps below:

- Press and hold **V** and **PROG** for 3 seconds to enter User Advanced Programming, the display will change to figure opposite.
- Press and hold **V**, **Λ** and **PROG** for 5 seconds to enter Installer Advanced Programming, the display will change to figure opposite.



- c) Use + and - keys to scroll backwards and forwards between options then **V** and **Λ** keys to change the option settings. The flashing digit on the right hand of the display indicates the number of the selected option. The large characters display the option value selected.
- d) To return to **RUN**, press and hold **PROG** until the display returns to **RUN** mode.

Option 30 - Set upper limit of temperature range

This allows the upper limit of the thermostat setting range to be electronically limited. Press + until Option 30 is displayed, use **V** and **Λ** to select required setting.



Setting	40 - 5°C (factory setting is 30°C)
----------------	------------------------------------

Option 31 - Set lower limit of temperature range

This allows the lower limit of the thermostat setting range to be electronically limited. Press + until Option 31 is displayed, use **V** and **Λ** to select required setting.



Setting	5 - 40°C (factory setting is 5°C)
----------------	-----------------------------------

Option 32 - Enable Off at lower limit

This enables an **OFF** function to be selected if a set point below the lower limit is selected. Press + until Option 32 is displayed, use **V** and **Λ** to select required setting.



Setting 0	Disabled
------------------	----------

Setting 1	Enabled (factory setting)
------------------	---------------------------

Option 33 - Enable On at upper limit

This enables an **ON** function to be selected if a set point above the upper limit is selected. Press + until Option 33 is displayed, use **V** and **Λ** to select required setting.



Setting 0	Disabled (factory setting)
------------------	----------------------------

Setting 1	Enabled
------------------	---------

Option 34 - Select On/Off or Chrono-proportional

This allows the thermostat to be set to run in On/Off mode or for a chrono-proportional cycle rate to be selected. Press + until Option 34 is displayed, use **V** and **Λ** to select required setting.



0	On/Off
3	3 cycles per hour
6	6 cycles per hour (factory setting)
9	9 cycles per hour
12	12 cycles per hour

Option 35 - Set integration time (Option 34 set to 3, 6, 9 or 12) (seek advice prior to adjusting)

This adjusts the integration time of the PI algorithm to increase control accuracy. It is only active if option 34 has been set to Chrono 3, 6, 9 or 12. It should only be adjusted after seeking advice from the manufacturer. Press + until Option 35 is displayed, use **V** and **Λ** to select required setting.



2.5	Integration time set to 2.5% (factory setting)
5	Integration time set to 5%
10	Integration time set to 10%

Option 36 - Set temperature override rule

This establishes the degree of temperature override available to the user. Press + until Option 36 is displayed, use **V** and **Λ** to select required setting.



Setting 0	No limit (factory setting)
Setting 1	Limited to $\pm 2^{\circ}\text{C}$
Setting 2	No override allowed

Option 37 - Set time duration of override rule (Option 36 set to 1 or 2)

This establishes the duration of a temperature override available to the user. Press + until Option 37 is displayed, use **V** and **Λ** to select required setting.



Setting 0 Next event (factory setting)

Setting 1 1 hour

Setting 2 2 hours

Setting 3 3 hours

Setting 4 4 hours

Option 40 - Number of Events per Day (Heating)

This sets the thermostat to operate with either 2, 4 or 6 switching events per day or to run it in stat mode. Press + until option 40 is displayed, use **Λ** or **V** to select required setting.

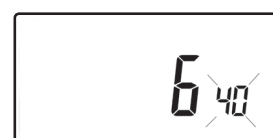

1 Stat mode

2 Two switching events per day

4 Four switching events per day

6 Six switching events per day (factory setting)

Option 41 - Operating Mode (Heating) (option 40 set to 2, 4, or 6)

This sets the thermostat to operate using either 5/2 day or 24 hour mode. Press + until option 41 is displayed, use **Λ** or **V** to select required setting.

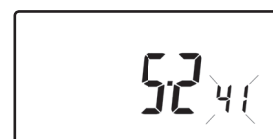

7 7 Day programming (factory setting)

5-2 or A-B 5-2 Day programming or A-B programming

24 24 hour programming

Option 60 - Number of events per day (Hot Water)

This sets the number of Hot Water on/off switching times per day. Press + until option 60 is displayed, use **Λ** or **V** to select required setting.

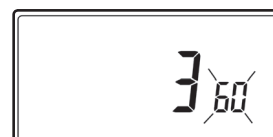

Setting 1 1 on/off event per day

Setting 2 2 on/off events per day

Setting 3 3 on/off events per day (factory setting)

Option 61 - Hot Water Event - Days per week	
This sets the schedule of Hot Water on/off switching times per week. Press + until Option 61 is displayed, use V and Λ to select required setting.	
24	24 Hour
5-2	Either 5+2 day or A+B days depending on user APM setting
7	7 Day (factory setting)

Option 70 - Keyboard disable rules	
This establishes the degree of functionality of the keyboard available to the user. It is only active if DIL switch 1 is set to "Disabled". Press + until Option 70 is displayed, use V and Λ to select required setting.	
Setting 0	Normal lock: Programming functions locked (factory setting)
Setting 1	Full lock: All keys are disabled

Option 71 - Random start rules (24V/230 Volt models only)	
This enables a random start on power-up following a power cut to reduce load on the electrical network. Random delay is in the range of 2 - 90 seconds. Press + until Option 71 is displayed, use V and Λ to select required setting.	
Setting 0	Disabled (factory setting)
Setting 1	Enabled

Option 72 - Owner site reference number	
This enables multi-site owners to store a site reference number in the thermostat. Press + until Option 72 is displayed, use V and Λ to select required setting.	
Setting	Any value between 00 and 99 can be set
Factory setting is 00	

Option 73 - Owner thermostat reference number

This enables site owners to store a thermostat reference number in the thermostat. Press + until Option 73 is displayed, use **V** and **Λ** to select required setting.



Setting Any value between 000 and 999 can be set

Factory setting is 000

Option 74 - Date format for calendar clock

This allows date format to be chosen. Press + until Option 74 is displayed, use **V** and **Λ** to select required setting.



Setting 0 European format (dd/mm/yy), (Factory setting)

Setting 1 North American format (mm/dd/yy)

Option 80 - Enable/Disable + Hrs Boost

Enables or disables the +Hrs button. use **V** and **Λ** to select required setting. Press + until Option 80 is displayed, use **V** and **Λ** to select required setting.



Setting 0 +Hrs Boost button disabled

Setting 1 +Hrs Boost button enabled (factory setting)

Option 81 - Thermostat calibration bias

This allows the thermostat calibration to be biased by up to $\pm 1.5^{\circ}\text{C}$. Press + until Option 81 is displayed, use **V** and **Λ** to select required setting.



Setting Any value between ± 1.5 in 0.5°C steps (Factory setting is 0°C)

Option 90 - Define remote sensor type	
This allows type of remote sensor input type to be defined. Press + until Option 90 is displayed, use V and Λ to select required setting.	
	
Setting 0	No remote sensor fitted
Setting 1	Remote room or duct sensor fitted, internal sensor disabled (factory setting)
Setting 2	Remote limit sensor fitted, refer to option 93 to define set-point
Setting 3	Configured as digital input for window, card reader or teleswitch, refer to option 94 to define o/c or s/c.
Setting 4	Outdoor sensor fitted internal sensor active, outdoor sensor used for display purposes only

Option 93 - Set limit sensor set-point (option 90 set to 2)	
This allows the thermostat limit sensor to be set, typical application is floor Heating. Press + until Option 93 is displayed, use V and Λ to select required setting. If the temperature sensed by the limit sensor exceeds the limit setting the output will be turned off until the temperature has dropped by 2°C. "F10" will flash in the display while the output is disabled.	
	
Setting	Any value between 20 - 50°C (Factory setting is 27°C)

Option 94 - Configure digital input switch type, "A" models only, (option 90 set to 3)	
This allows switch type of digital input to be configured. Press + until Option 94 is displayed, use V and Λ to select required setting.	
	
Setting 0	Contacts NC, open circuit contact to force unit into thermostat mode, short circuit contacts to return to normal operation
Setting 1	Contacts NO, short circuit contacts to force unit into thermostat mode, open circuit contacts to return to normal operation (Factory setting)

TACMA

THE ASSOCIATION
OF CONTROLS
MANUFACTURERS

11385

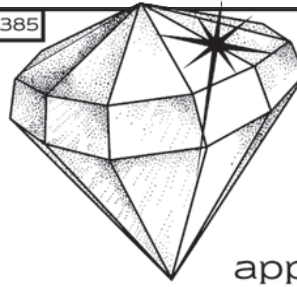

Crystal Mark

Clarity
approved by
Plain English Campaign

GB

User Instructions

What is a programmable room thermostat?

... an explanation for householders

A programmable room thermostat is both a programmer and a room thermostat. A programmer allows you to set 'On' and 'Off' time periods to suit your own lifestyle. A room thermostat works by sensing the air temperature, switching on the heating when the air temperature falls below the thermostat setting, and switching it off once this set temperature has been reached.

So, a programmable room thermostat lets you choose what times you want the heating to be on, and what temperature it should reach while it is on. It will allow you to select different temperatures in your home at different times of the day (and days of the week) to meet your particular needs.

Turning a programmable room thermostat to a higher setting will not make the room heat up any faster. How quickly the room heats up depends on the design of the heating system, for example, the size of boiler and radiators.

Neither does the setting affect how quickly the room cools down. Turning a programmable room thermostat to a lower setting will result in the room being controlled at a lower temperature, and saves energy.

The way to set and use your programmable room thermostat is to find the lowest temperature settings that you are comfortable with at the different times you have chosen, and then leave it alone to do its job. The best way to do this is to set low temperatures first, say 18°C, and then turn them up by one degree each day until you are comfortable with the temperatures. You won't have to adjust the thermostat further. Any adjustments above these settings will waste energy and cost you more money.

If your heating system is a boiler with radiators, there will usually be only one programmable room thermostat to control the whole house. But you can have different temperatures in individual rooms by installing thermostatic radiator valves (TRVs) on individual radiators. If you don't have TRVs, you should choose a temperature that is reasonable for the whole house. If you do have TRVs, you can choose a slightly higher setting to make sure that even the coldest room is comfortable, then prevent any overheating in other rooms by adjusting the TRVs.

The time on the programmer must be correct. Some types have to be adjusted in spring and autumn at the changes between Greenwich Mean Time and British Summer Time.

You may be able to temporarily adjust the heating programme, for example, 'Override', 'Advance' or 'Boost'. These are explained in the manufacturer's instructions.

Programmable room thermostats need a free flow of air to sense the temperature, so they must not be covered by curtains or blocked by furniture. Nearby electric fires, televisions, wall or table lamps may prevent the thermostat from working properly.

GB User Instructions

An introduction to your programmable room thermostat

The TP9000 is a programmable thermostat designed to control both your Hot Water and Heating.

Depending on the setting value in the Installer Advanced Programming (option 41) you can have 7-day, 5-2 day or 24 hour programming. A full explanation of these different methods is located on page 20.

The thermostat can also be set by you to provide two different programming blocks which can then be assigned to any day of the week, this is referred to as A/B programme operation.

The Heating side of the TP9000 can be set by your installer to provide up to 2, 4 or 6 time and temperature settings each day, whereas the Hot Water can be set to provide 1, 2 or 3 on/off periods each day.

The thermostat also features useful overrides, including a programmable frost setting.

The TP9000 has some advanced features which the installer will set-up if they are required. There are also a number of advanced features which can be set up by you. These advanced settings alter the way that your thermostat operates, some also affect the programming functions and the user overrides. Please read the **User Advanced Programming** instructions before programming the unit (see page 33).

General Operation

The TP9000 has two distinct display modes - one for Hot Water, one for Central Heating. The currently selected mode is indicated by a bar at the bottom of the LCD screen when in run mode. The right bar is for Heating, the left bar is for Hot Water.



When programming the TP9000 it is important to be aware of which mode is active before beginning programming. To toggle between modes, press the CH/HW button. The display will change and the indicator bar at the bottom will move to reflect which mode is selected. The flame (🔥) and tap (🚰) symbols are used in conjunction with the LED's to show the current output status (on/off). The output status is always shown for both Heating and Hot Water regardless of the display mode.

Preset programmes

Your TP9000 comes ready programmed with a set of operating times and temperatures which suit most people. Please remember that some of the options available will depend on how the installer has set up the unit.

Central Heating

<i>Weekdays (Mon-Fri)</i>		
Event	Time	Temp. °C
1	06:30	20
2	08:30	15
3	11:30	20
4	13:30	15
5	16:30	21
6	22:30	15
Note: these are also times for Block "A" programmes		

<i>Weekend (Sat-Sun)</i>		
Event	Time	Temp. °C
1	07:30	20
2	09:30	20
3	11:30	20
4	13:30	20
5	16:30	21
6	22:30	15
Note: these are also times for Block "B" programmes		

Note: If set up for 4 events per day, events 3 & 4 are skipped. If set up for 2 events per day, events 2, 3, 4 & 5 are skipped. In both cases the events are re-numbered.



Hot Water

<i>Weekdays (Mon-Fri)</i>		
Event	Time	Temp. °C
1	06:30	On
2	08:30	Off
3	11:30	On
4	13:30	Off
5	16:30	On
6	22:30	Off
Note: these are also times for Block "A" programmes		

<i>Weekend (Sat-Sun)</i>		
Event	Time	Temp. °C
1	07:30	On
2	09:30	Off
3	11:30	On
4	13:30	Off
5	16:30	On
6	22:30	Off
Note: these are also times for Block "B" programmes		

Note: If set up for two on/off events per day, events 3 and 4 are skipped. If set up for one on/off event per day, events 2, 3, 4 & 5 are skipped. In both cases the events are re-numbered.

Customising the display

For the sake of clarity, the instructions assume that the display setting uses a 24 hour clock, °C and that days of the week are shown as text. All of these settings can be personalised after the thermostat has been programmed, see page 27

Setting the correct date and time

Your TP9000 incorporates a real time clock with calendar function that automatically changes time in both Spring and Autumn. The time and date is set in the factory for the UK time zone, and does not normally require adjustment. If you live in another time zone refer to "Time zone offset" on page 34. However, should it be found necessary to adjust time or date for any other reason refer to the following instructions.

Setting the date

GB

Press and hold **Λ** and **PROG** for 3 seconds, to display date in dd/mm/yy format.

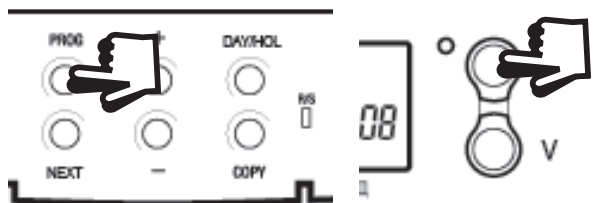

The **YEAR** number will flash, use **Λ** or **V** to correct the year.

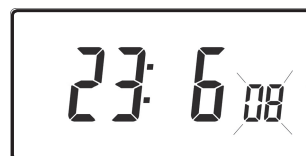

Use - or + to move to **MONTH**, then use **Λ** or **V** to correct month.



Use - or + to move to **DATE** in month, then use **Λ** or **V** to correct day in month.



If you attempt to select an invalid date the unit software will reject it and apply the nearest valid date. It is recommended that date is set in the order, yy/mm/dd.

Setting the correct time

After setting the date press **PROG** to display the time. The time display will flash on and off.

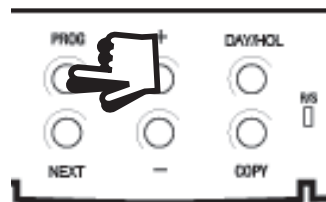

Use the + and - buttons to set the correct time (press and hold to change in 10 min. increments).



Setting the correct day

The day of the week is set automatically. Press **PROG** to return to normal operation (**RUN**).



If you are happy with the preset times shown in the table on page 17 you need take no further action.

Changing the preset programmes

Before you change the preset programmes

Your installer will have set the unit to operate in one of the following modes:

- 7 day - each day has independent times and temperatures offering full flexibility of programming (page 21).
- 5/2 day - one set of programmes for weekdays and another for weekends (page 21).
- 24 hr - one set of programmes for the whole of the week (page 22).

Alternatively

- A/B - The unit can also be set by you to provide two programme blocks, either of which can be applied to different days of the week. If this is required refer to page 23 for instructions on how to turn on this feature.

Please Note

The unit must be programmed in sequence, event times cannot be set out of sequence.

If you want to leave a preset time as it is, simply press **NEXT** to move to the next setting.

If you want to return the unit to **RUN**, press **PROG** and hold until the display returns to the previous **RUN** mode. Alternatively leave alone and the unit will automatically return to **RUN** after 2 minutes.

Your installer will have set your unit to programme 6, 4 or 2 events per day for Heating, or 1, 2 or 3 events per day for Hot Water. This will determine the number of events per day that you are able to programme.

Before beginning programming the unit remember to check that the correct function is selected i.e. Heating or Hot Water by using the CH/HW button. 

Changing the preset programmes in 7 day mode

GB

- a) Press PROG once until the display shows the first preset time and temperature



- b) Use the + and - buttons to adjust the time (press and hold to adjust in 10 minute increments)

- c) Use the **▲** and **▼** buttons to adjust the required temperature (CH only)

- d) Press NEXT to move to the next preset time and/or temperature (Event 2)



- e) Once all events for the day have been programmed, press DAY/HOL to move to the next day

- f) Repeat steps **b, c, d & e** to programme the remaining weeks events.

- g) Press and hold PROG to return to the main screen.

Changing the preset programmes in 5/2 day mode

For Weekdays

- a) Press **PROG** until the first preset time and temperature (Event 1 Days MON, TUE, WED, THU, FRI)



- b) Use the + and - buttons to adjust the **TIME** (press and hold to change in 10 minute increments).

- c) Use the **▲** and **▼** buttons to adjust the required **TEMPERATURE** (CH only).

- d) Press **NEXT** to move to the next preset time and/or temperature (Event 2).



- e) Repeat steps b, c, & d to programme the remaining weekday events.

- f) Press **DAY/HOL** to move on to weekend events.



For Weekends

Press **PROG** until the first preset time and temperature (Event 1 Days SAT, SUN) appears in display.

Repeat steps **b, c, & d** above to programme the remaining weekend events.

Press **PROG** to return to the main screen.

Changing the preset programmes in 24 hour mode

- a) Press **PROG** until the first preset time and temperature (Event 1 for all days of the week) appears in display.



- b) Use the + and - buttons to adjust the **TIME** (press and hold to change in 10 min increments).
- c) Use the **▲** and **▼** buttons to adjust the required **TEMPERATURE (CH only)**.

- d) Press **NEXT** to move to the next preset time and/or temperature (Event 2).

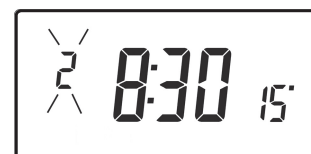

- e) Repeat steps b, c, & d to programme the remaining events.
- f) Press **DAY/HOL** to move on to weekend events.

Changing preset programmes for AB programming



(Installer option 41 must be set to 5-2 day mode)

Press and hold **PROG** and **V** for 3 seconds. The display will change to the figure opposite. This will take you into **User Advanced Programming** option 1.



Use **Λ** and **V** keys to enable or disable the function (1=enabled, 0=disabled).



Press **PROG** for 5 seconds until the display returns to previous **RUN** mode.

Press **PROG** once, the display will change to show the default days assigned to programme "A" (days MON, TUE, WED, THU, FRI).

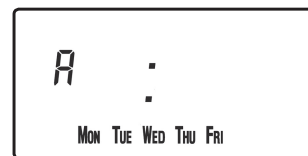

Use the **+** and **-** keys to scroll forwards or backwards through the days of the week.

To deselect a day press **V**, (for example TUE). To select a day press **Λ** (for example SUN).

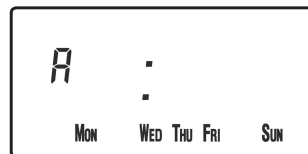

Any deselected days are automatically assigned to programme "B".

Programming "A" programme days and events

a) Press **PROG** until the first preset time and/or temperature (Event 1 for Programme A) appears in display.



b) Use the **+** and **-** buttons to adjust the **TIME** (press and hold to change in 10 minute increments).

c) Use the **Λ** and **V** buttons to adjust the required **TEMPERATURE**.

d) Press **NEXT** to move to the next preset time and temperature (CH only) (Event 2).

e) Repeat steps b, c, & d to programme the remaining events.

- Press **DAY/HOL** until the first preset time and temperature (Event 1 for Programme B) appears in the display.
- Use the + and - buttons to adjust the **TIME** (press and hold to change in 10 minute increments).
- Use the **Λ** and **V** buttons to adjust the required **TEMPERATURE (CH only)**.
- Press **NEXT** to move to the next preset time and/or temperature (Event 2).
- Repeat steps b, c, & d to programme the remaining events.



Running the programme

Press **PROG** to return to previous **RUN** mode. The Heating will now follow the times and temperatures programmed.



Copy functions explained

There are 2 possible copy functions available. These are; Standard Copy and Enhanced Copy. Copy functions are enabled/disabled in the Advanced Programming Options (page 33)

Standard Copy: Pressing copy will copy the previous days events into the displayed day. The unit will then display the 1st event for the new day. This copy function is present only if the unit is set to run in 5+2 or 7 day mode.

Enhanced copy: The enhanced copy function is available in 7 day mode only. This allows any day to be copied to any other day, or days. To use the enhanced copy function, go into the event programming using the **PROG** button, then:

- 1) use the **DAY** button to find the day to be copied from
- 2) press the **COPY** button to select the day to be copied from. When selected, the day should begin to flash.
- 3) use the **DAY** button to find the day to be copied to
- 4) press **COPY** button to copy the selected day
- 5) repeat steps 3 and 4 to select and copy other days
- 6) to stop copying, use the **DAY** button to go back to the flashing day and press the **COPY** button. The previously flashing day will stop flashing to indicate it has been de-selected.

Holiday programme

The TP9000 is equipped with a holiday mode that enables it to automatically bring back on the Heating and Hot Water when returning from holiday. During the period when the unit is in holiday mode, the Hot Water is turned off, and the central Heating is placed in frost protection mode 

To set up the holiday programme, please follow the below steps:

- a) Press and hold **DAY/HOL**



- b) Use the **▲** and **▼** buttons to set the year



- c) Use the + button to move to the month. Use the **▲** and **▼** buttons to set the month



- d) Use the + button to move to the day. Use the **▲** and **▼** buttons to set the day



- e) To exit and activate the holiday mode press

DAY/HOL once. The display will change, Heating and Hot Water will be switched off. The unit will stay in this state until the programmed return date, at which point it will resume normal operation.



- f) Once in holiday mode, the return modes for both the heating and hot water can be set. Use the CH/HW button to change between heating and hot water display mode.
- g) The Heating set temperature for the duration of the holiday mode can be adjusted by selecting the Heating display mode with the CH/HW button and then adjusting the set temperature using the (image of Up button) and image of Down button) buttons.
- h) Holiday mode can be manually ended at any time by pressing the DAY button

User Overrides

GB

User Instructions

Altering the display to show time or temperature (Heating Mode)

Press + and - together to change between settings.

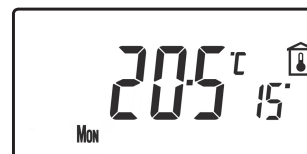

Temporarily alter current programmed temperature

Press **Λ** or **V** until required temperature is displayed. Please note that your installer may have restricted both upper and lower temperature settings and the temperature override limits.

This override will automatically be cancelled at the beginning of the next programmed event. Please note that your installer may have restricted the duration of the override to something other than next event. In this case the override arrow will flash to indicate a timed override is active during the next event

To change day of week legends from numbers to text

Press **Λ** and - together to toggle between day numbers and text.

To change time display between 12 hour and 24 hour clock

Press **Λ** and + together to toggle between 12 and 24 hour clock.

To change between °C and °F scaling

Press **V** and **-** together to toggle between °C and °F temperature scaling.

Thermostat mode (Heating mode only)

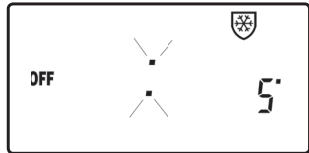
- A constant temperature of between 5-30°C can be selected if required. This can provide frost protection for periods away from home, it can also be used to provide untimed higher temperatures if, for example, a family member is sick.
- Press **Λ** and **V** together to enter thermostat mode. The default setting is 5°C, but this can be reprogrammed, see **User Advanced Programming**, step 10, (page 34).
- A frost protection symbol (snowflake in a shield) will appear in the display when the selected temperature is equal to or less than the programmed frost protection setting.
 
- Use the **Λ** or **V** buttons to change the temperature away from the programmed frost protection temperature to another value.
- To return to automatic programming press both **Λ** and **V** together.
- Alternately, Thermostat mode can be accessed via the **MODE** button (see page 31)

Changing the clock forwards and backwards

This is handled automatically, however, if the manual changeover has been selected (User Advanced Programming step 3 on page 34) follow the instructions below.

To change from Summer to Winter (clocks back)

With clock display showing, press and hold **-** button until time moves back.

To change from Winter to summer (clocks forward)

With clock display showing, press and hold **+** button until time moves forward.

Remote override into and out of thermostat mode

Selected models are available with a feature which allows a telephone activated switch or window contacts to step the unit into or out of thermostat mode.

The required temperature to be maintained when the building is unoccupied, or when windows are open, must first be set up in **User Advanced Programming**, step 10, (page 34).

To locally override this feature press either both **Λ** and **V** together, or press the **MODE** button.

Delay start feature

Your thermostat includes an optional delay start feature to hold off the Heating for a time on mild days when the room temperature at the start of an event is close to the programmed value. If you have enabled this function it can be overridden by pressing either **Λ** or **V** buttons. To enable this feature, please refer to **User Advanced Programming**, step 11, (page 35).

When this function is active, the set temperature will flash on the display and an hourglass symbol will be displayed.

Optimum start control (OSC)

Your thermostat includes an optional optimum start control. This feature allows you to set the time at which you require a room temperature by. The thermostat then calculates how soon before the event time the system must be turned up to ensure that the room is at the temperature by the required time. A full description of this and how to enable it and set it up is given in **User Advanced Programming**, steps 12 & 13, (page 36). When this function is active, the set temperature will flash on the display

Temporary override buttons

Sometimes you may need to change the way you use your Heating temporarily, i.e. due to unusually cold weather. The TP9000 has two convenient overrides which can be selected without affecting the set programme.

+1/+2/+3 hr
override

Mode select
button (auto/all
day/on/off)

CH/HW
button

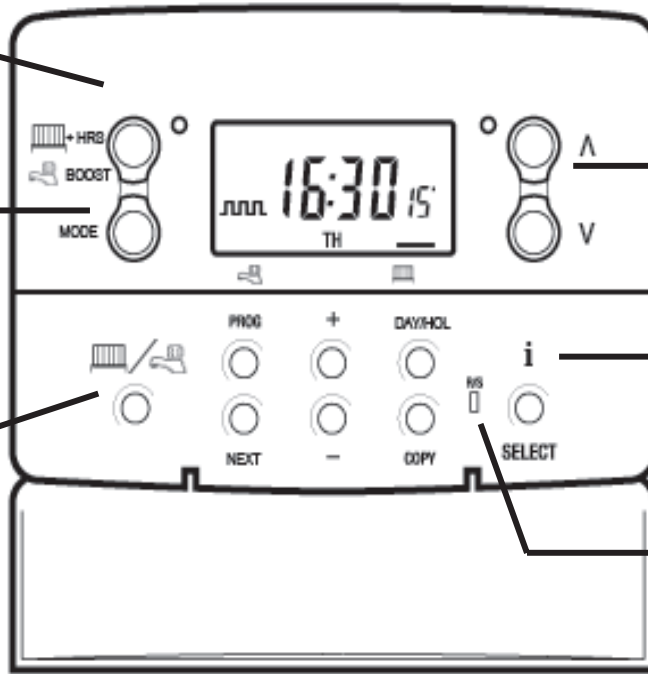

Temperature
adjustment
buttons

INFO button

RESET



The grey buttons next to the **radiator and tap symbol** is the + HRS button for heating and the **BOOST** button for the Hot Water.

For Water display mode, pressing this button once, twice or three times when the system is in **OFF**, **AUTO** or **ALLDAY** mode will cause the Hot Water to remain on for an extra 1, 2 or 3 hours if already on, or will switch the water on for 1, 2 or 3 hours if currently off. **BOOST +1, +2 or +3 HRS** will be shown in the display.

For Heating display mode, pressing the +HRS button once, twice or three times will extend the current time/temperature period for 1, 2 or 3 hours, but **does not** operate if the thermostat is in the **OFF** or **FROST PROTECTION** mode. +1, +2 or +3 **HRS** will be shown in the display. Pressing this button for a fourth time will cancel the **+HRS BOOST** function.

MODE Pressing this button will alternate between setting the unit in **OFF** (Thermostat), **AUTO** or **ALLDAY** modes for **HEATING** or **ON, OFF, AUTO** or **ALLDAY** modes for **WATER**. In **AUTO** mode, all programmed events will run, whereas in **ALLDAY** mode, only the first and last events will run. If set for two events per day for Heating, or one **ON/OFF** event for Water then **AUTO** and **ALLDAY** modes are the same. The display will show how many events are to run:



Indicates that unit is in **ALLDAY** or **AUTO** mode with 2 events per day for 1 On/Off for Hot Water.



Indicates that the unit is in **AUTO** mode with 4 events per day for heat or 2 ON/OFF for Hot Water.



Indicates that the unit is in **AUTO** mode with 6 events per day for heat or 3 for Hot Water.

ON Indicates Hot Water is permanently on (Applies to Hot Water only)

OFF Indicates permanently off for Hot Water or Thermostat mode (see page 28) for Heating

i The INFO button is used to display information about either the next programmed event for the currently selected mode (central Heating or Hot Water) to display the outdoor temperature (if outdoor sensor is fitted) and to show the Service Due Date if set. Below is a more detailed explanation of operation:

If no outdoor sensor is fitted:

Pressing the INFO button will display the time of the next event according to the programmed times. The event time shown will include any +HRS or BOOST extensions. If the next event time is shown flashing, this represents an approximate time due to Optimum Start, Delayed Start or a timed override being active.



If an outdoor sensor is fitted:

Pressing the INFO button will display the current outdoor temperature, followed by the lowest and highest outdoor temperatures in the last 24 hours.

If Service Due date is set:

Pressing the INFO button will display the date the service is due.

If in holiday mode:

Pressing the INFO button will display the holiday end date.

User Advanced Programming Options

Important: The thermostat has been set in the factory to suit most situations, however, there are additional optional settings which can improve the comfort, convenience and energy effectiveness of your thermostat. These are set in the **User Advanced Programming** and **Installer Advanced Programming** modes.

To access User Advanced Programming

Press and hold **V** and **PROG** for 3 seconds. This will take you into **User Advanced Programming**. Use **+** and **-** keys to scroll backwards and forwards between options then **Λ** and **V** keys to change option settings. The flashing digit on the right hand of the display indicates the number of the selected option.

Option 1 - Enable or disable A/B programming (Option 41 and/or 61 set to 5+2)	
This enables or disables the A/B programming option. Press + until Option 1 is displayed, use Λ and V to select required setting.	
	
Setting 0	Disabled, unit operates as 5+2
Setting 1	Enabled: activates A/B programming

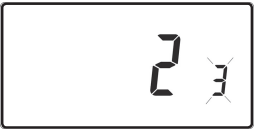
Option 2 - Enable/Disable Advanced Programming (Option 41 and/or 61 set to 7 Day)	
This option enables or disables the Advanced Copy Functionality. Press + until option 2 is selected, use Λ or V to select required setting	
	
Setting 0	Advanced Copy disabled (standard copy mode)
Setting 1	Advanced Copy enabled

Option 3 - Calendar clock rules	
This establishes the rules that the automatic calendar clock follows to calculate changes between summer and winter time. Press + until Option 3 is displayed, use Λ and V to select required setting	
	
Setting 0	Disabled.
Setting 1	Manual: user must change using + to advance and - to retard displayed time.
Setting 2	European rules. (Factory Setting)
Setting 3	USA rules (2007 onwards)
Setting 4	USA rules (pre-2007)

Option 4 - Time zone offset	
This feature allows the time zone to be established and corrects time display. Press + until Option 4 is displayed, use Λ and V to select required setting	
	
Setting 0	UK models: this feature should be left at the factory setting of 0.
Setting 1	Central European time models: this feature should be left at the factory setting of +1:00.
-12 Hours +14 Hours	
Rest of World: use Λ and V keys to select offset from Universal time (GMT) for the location in which the thermostat is being installed.	

Option 10 - Frost/ thermostat mode setting	
This feature allows the default frost/thermostat mode temperature to be set. Press + until Option 10 is displayed, use Λ and V to select required setting.	
	
5-40°C - Factory setting is 5°C, but can be changed to any value between 5-40°C.	

Option 11 - Start-up method	
Your thermostat can start up the system in three different ways. Press + until Option 11 is displayed, use Λ and V to select required setting.	
	
Setting 0	Normal: Heating is turned up or down at the programmed times.
Setting 1	Optimum start control (OSC) (or Comfort Setting): This allows you to programme the time at which you would like to be up to the required temperature. The thermostat then calculates how soon before the required time the Heating is turned up. This will vary with weather conditions ranging from a maximum of 120 minutes to 0 minutes before the programmed event time. This setting must be used together with option 12 to match the optimiser setting to the building in which it is installed.
Setting 2	Delay start (or Economy Setting): This is an alternative to OSC. Set the event times in the normal way taking into account the time that the building takes to heat on an average day. The thermostat monitors switch on time, actual temperature and wanted temperature and delays the start of the Heating if the actual temperature is close to the programmed temperature.

Option 12 - Optimum start control pre-heat setting (Option 11 set to 1)

Press + until Option 12 is displayed, use **Λ** and **V** to select required setting (only active if Option 11 is set to 1).



The optimum start control must be adjusted to match the building energy characteristics. Use the **Λ** and **V** keys to selected the required pre-heat period. The table below suggests typical settings.

If the building fails to reach temperature on time, increase the setting by 15 minute steps each day until the correct setting is found.

If the building reaches temperature ahead of time, decrease the setting by 15 minute steps each day until the correct setting is found.

0:15	15 mins, warm air systems, well insulated building.
0:30	30 mins, warm air systems, well insulated building.
0:45	45 mins, warm air system poorly insulated building.
1:00	60 mins, radiator system, light weight well insulated building. (Factory setting)
1:15	75 mins, radiator system, light weight medium insulation.
1:30	90 mins, radiator system, medium weight poorly insulation.
1:45	105 mins, radiator system, heavy weight building, well insulated.
2:00	120 mins, radiator system, heavy weight building, poorly insulated.

Option 13 - Optimum start control/Delayed start event setting (Option 11 set to 1 or 2)

The Optimum start or delayed start control can be applied to event 1 only or to each event of the day which requires a higher temperature than the previous event. Press + until Option 13 is displayed, use **Λ** and **V** to select required setting (only active if Option 11 is set to 1 or 2).



Setting 0	Applies only to first event of day. (Factory setting)
Setting 1	Applies to each event of the day that requires a higher temperature compared to previous event.

Overview of installer selectable features which may affect the operation of your thermostat

Temperature range limitation

This allows the installer to programme both upper and lower temperature limits. It may limit the upper and lower temperature that you are able to set on the thermostat.

Temperature override limitation

This allows the installer to limit the number of degrees that you can override the programmed temperature by, it also allows the installer to set rules regarding how long a temperature override will remain in place.

Keyboard lock

This allows the installer to limit or lock the keyboard to prevent unauthorised changes to programme values and limits overrides.

Service Interval Timer

- If the property is owned by a landlord he may, for gas safety reasons, have instructed the installer to set the service interval timer.
- If set, 28 days prior to the service due date, a visual and audible warning will start each day at noon. The audible warning will last for 10 seconds and will be repeated every hour until a button is pressed to cancel it. If cancelled the alarm will recommence the following day at noon.
- If the boiler is not serviced before the due date, a visual and audible warning will start each day at noon. The audible warning will last for 1 minute and will be repeated every hour until a button is pressed to cancel it. If cancelled the alarm will recommence the following day at noon.
- In addition, all overrides and programming buttons will be disabled and the Heating and Hot Water may operate for a limited amount of time each hour.
- The installer may cancel or reset the service interval timer as part of the boiler service.
- This is a gas safety feature that can only be accessed by an installer.

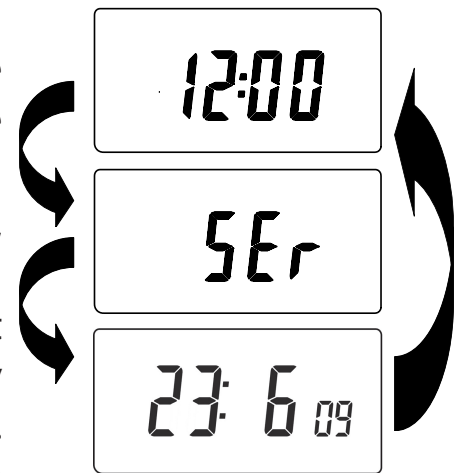

Service Interval Date

Resetting the unit

Partial reset: Press **RESET** (used to restart micro-computer) if display freezes for any reason. This does not reset any programme, clock or date. It is recommended that this is done at time of installation.

User full reset: Press **RESET** whilst holding down **PROG** button. This resets event times and any User Advanced Programme setting, but does not reset time or date.

Installer full reset: This is only available to the installer. In addition to the above all of the Installer Advanced Programming settings are returned to factory settings, however, time, date and service due date are not reset.

Installer Settings		
Option	Description	Installer Setting
Option 30	Set upper limit of temperature range	
Option 31	Set lower limit of temperature range	
Option 32	Enable Off at lower limit	
Option 33	Enable On at upper limit	
Option 34	Select On/Off or Chrono-proportional	
Option 35	Set Integration Time	
Option 36	Set temperature override rule	
Option 37	Set time duration of override rule	
Option 40	Number of events per day (Heating)	
Option 41	Operating mode (Heating)	
Option 60	Number of events per day (Hot Water)	
Option 61	Operating Mode (Water)	
Option 70	Keyboard disable rules	
Option 71	Random start rules	
Option 72	Owner site reference number	
Option 73	Owner thermostat reference number	
Option 74	Date format for calendar clock	
Option 80	Enable/Disable + hrs boost	
Option 81	Thermostat calibration bias	
Option 90	Define remote sensor type	
Option 93	Set limit sensor set-point	
Option 94	Configure digital input switch type	

User Settings		
Option	Description	User Settings
Option 1	Enable/disable A/B programming	
Option 2	Enable/Disable advanced programming	
Option 3	Calendar clock rules	
Option 4	Time zone offset	
Option 10	Frost/thermostat mode setting	
Option 11	Start-up method	
Option 12	Optimum start control pre-heat setting	
Option 13	Optimum start control/delayed start event setting	

www.danfoss.com/BusinessAreas/Heating

This product complies with the following EC Directives:
Electro-Magnetic Compatibility Directive.
(EMC) (2004/108/EC)
Low Voltage Directive.
(LVD) (2006/95/EC)

